



# RESIDENTIAL CATALOG

## GUTTER SYSTEM

- Gutter System Elements
- Range of colors
- Installation guide

## GENERAL DESCRIPTION

The BILKA gutter system is made of hot galvanized steel, with multilayer protection on both sides for a perfect behavior in time. The element joining system is simple, fast and efficient, does not allow rainwater to pour down the facade or to infiltrate in the house foundation and walls, thus protecting the whole building and ensuring a higher useful life.

The production of the BILKA system elements is based on the Swedish technology, using high-quality Swedish steel (0.6 mm thick), galvanized on both sides (275 g/sqm) and covered with polymer paint (2x35 microns).

- The polymer paint layer confers products a special surface smoothness, high color stability and solid resistance to rainwater and atmospheric pollutants.
  - The five layers building and protecting the metal band ensure that each element is corrosion-proof and provide an extended useful life of such products.
- “ This is why the BILKA system guarantees very long-term resistance, whereby the only maintenance operation required resides in the cleaning of the gutters.



1	2	3	4	5
Steel	Zinc layer	Primer layer	Passivation layer	Paint layer

Parameter	Glossy shade	Matte shade	Standard
Use	Outer	Outer	-
Thickness of the surface	35 µm/35 µm	40 µm/40 µm	ISO 2808
Surface thickness tolerance	6 µm	6 µm	EN 10169-1
Varnish	40	<5	EN 13523-2
The minimum internal radius bend	0.5 x t	0.5 x t	EN 13523-7
Minimum formation temperature	- 15°C	15°C	-
Scratch resistance	35N	30N	EN 13523-5
Stain resistance	very good	very good	-
Maximum working temperature	+ 100°C	+ 100°C	-
UV Category	RUV3	RUV4	prEN 10169-2
Corrosion resistance category	RC5	RC5	prEN 10169-2
Zinc coating	275 g/sqm	275 g/sqm	-

BILKA gutter systems is available in two dimensional groups, 150/100, 125/90 and also available in 13 color options. The size and color options enable achievement of the appropriate individual combinations and to match the roof color.



\* Color shades may differ from the real ones. In order to be sure, do no hesitate to ask the color chart from the BILKA representative.

## GUTTER SYSTEM ADVANTAGES



The gutter system also called controlled evacuation system of the pluvial water from the roof or collecting and discharge system of pluvial waters, as it is called, is designated to take over the water from the roof and to direct it to the sewer system.

“ Given the extremely important role, its choice must be done very carefully.

Below are some advantages of the gutter system BILKA.

### **SUSTAINABILITY**

If it is assembled according to the recommendations of specialists, the BILKA gutter system must have the same lifespan as the construction on which it was assembled, at least 60 years.

“ It is resistant to rain, wind, snow and is recommended even in the areas with aggressive weather and heavy rain falls.

### **RELIABILITY**

We know the importance of the construction of a house.

Therefore, the gutter system BILKA is designed to be used for any type of construction or shape of the roof.

“ Regardless of the shape and size that a roof has, the gutter system can be assembled without difficulties.

### **WIDE RANGE OF COLOURS**

BILKA manufactures the gutter system in 13 colour variants, thus, at BILKA you can find the gutter system to match in terms of colour with the rest of the construction elements.

### **PERFECT TIGHTNESS**

The joining system of the elements of the gutter system BILKA, does not allow the leakage of pluvial waters on the facade of the building or the infiltration in the foundation and walls of the house.

“ Thus, the structure of the construction is being protected ensuring a higher lifespan.

### **EASY ASSEMBLAGE**

In order not to have difficulties in the assemblage, the BILKA gutter system is assembled easily and quickly, just like a Lego game.

“ The elements are produced so as to achieve perfect bonding without the need for other fastening systems such as wood screws which in time may jeopardize the efficiency of the pluvial system.

### **UNDENIABLE AESTHETICS**

The gutter system is the one that encloses the entire roof.

It should highlight the beauty of the building.

“ The size and colour variants give the possibility of making some more suitable individual combinations, to match the colour of the roof and to integrate with the architectural style of the community to which the construction belongs.

# GUTTER SYSTEM ELEMENTS

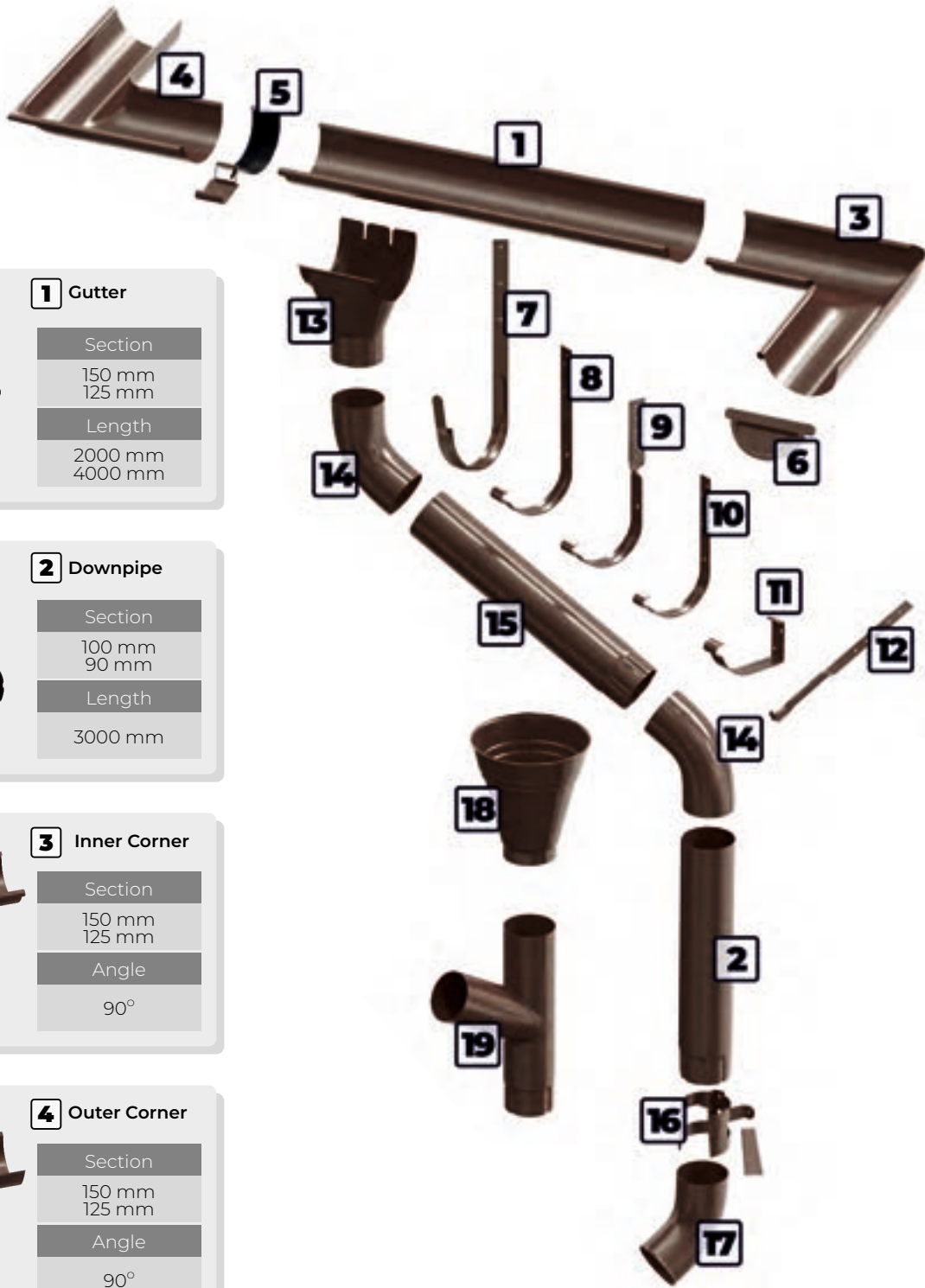

**1 Gutter**

Section	150 mm 125 mm
Length	2000 mm 4000 mm

**2 Downpipe**

Section	100 mm 90 mm
Length	3000 mm

**3 Inner Corner**

Section	150 mm 125 mm
Angle	90°

**4 Outer Corner**

Section	150 mm 125 mm
Angle	90°

**5 Gutter Joining Element**

Section	150 mm 125 mm
---------	------------------

**6 Gutter Stop End**

Section	150 mm 125 mm
---------	------------------

**7 Gutter Hook 300**

Section	150 mm 300 mm
---------	------------------

**8** Gutter Hook 210

Section
150 mm 125 mm
Length
210 mm

**14** 60° Elbow

Section
100 mm 90 mm

**20** Drain Branch

Section
100 mm 90 mm

**9** Twisted Hook

Section
150 mm 125 mm

**15** Downpipe Connector

Section
100 mm 90 mm
Length
1000 mm

**10** Gutter Hook 160

Section
150 mm 125 mm
Length
160 mm

**16** Downpipe Clamps

Section
100 mm 90 mm

**11** Combi hook

Section
150 mm 125 mm

**17** Discharge Elbow

Section
100 mm 90 mm

**12** Gutter Flange

Section
150 mm 125 mm
Length
210 mm

**18** Funnel

Section
100 mm 90 mm

**13** Running Outlet

Section
150 / 100 mm 125 / 90 mm

**19** Branch Pipe

Section
100 mm 90 mm

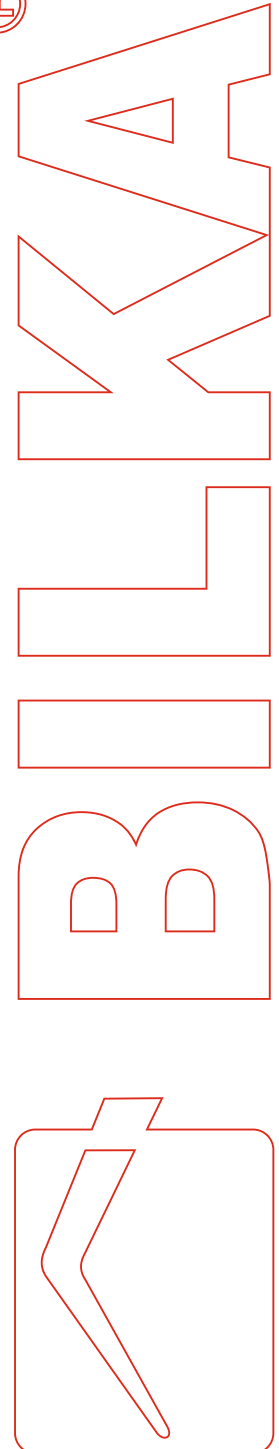



# INSTALLATION **GUIDE**

## STEP 1 - SELECTING THE SIZE OF THE GUTTER SYSTEM

The components of the BILKA gutter system are available in two type sizes:

- 125 and 150 mm: for gutters and their related elements, where size means the diameter of the elements;
- 90 and 100 mm: for downspouts and their related elements, where size means the diameter of the elements

If 125 mm gutters are selected, the corresponding (90 mm) downspouts must be selected.

If 150 mm gutters are selected, the corresponding (100 mm) downspouts must be selected.

“ The 125 mm elements are NOT compatible with the 100 mm elements, nor are the 150 mm elements with the 90 mm elements.  
“ Always use the 125/90 and 150/100 combinations.

The size of the gutter system should be selected depending on the following:

- The estimated quantity of rainfall that will flow down each gutter;
- The estimated quantity of rainfall that will be collected and guided by each downspout.

The size (diameter) of the gutters and downspouts shall be selected depending on the roof area or the quantity of water that must be collected and discharged.

- For areas of up to 100 square meters the 125/90 gutter system should be selected.
- For areas exceeding 100 square meters the 150/100 gutter system should be selected.

The above sizes are recommended as minimum requirements for the efficient collection of rainwater, for more accurate data please consult with the BILKA specialist.

### GENERAL INSTALLATION PRINCIPLES

- The installation of the roof/gutter system involves working at heights and risk of injury, therefore it is important for the fitters to wear protective equipment such as fixed ropes, helmets, gloves. In addition, tinner tools are required to cut the tile panels / accessories / rainwater system components (scissors for straight cuts, cutter, coated wire, lines for the alignment of the gutters, tinner marker, wedge hammer, grooved prism, folding pliers, pliers, screwdriver machine and proper bits for it).
- It is prohibited to cut the products using abrasive blades or other cutting tools that cause excessive local heating of the processed parts (failure to comply with this requirement is considered a breach of the warranty conditions).
- Wear shoes with soft soles when stepping on the cover, and only step on the area where the wood laths are placed (the sole must be regularly checked for any trimmings).
- During installation the trimmings must be removed from the surface of the products using a soft brush.



## STEP 2 - IDENTIFICATION OF THE WATER DRAINAGE COLUMNS

The required number of gutters and downspouts depends on the architecture of each house, but also on the architecture of the roof. The gutter must have the same length as the rain shadow.

“ It is recommended to have at least one downspout for each 8 linear meters of gutter.

Before installation it is important to prepare a drawing of the rainwater system to identify the drainage columns and the connectors. The slope of the gutter is determined and the hooks are installed depending on the number of downspouts. The downspouts are usually installed at the corners of the houses, unless otherwise required, in order to prevent them from affecting the design of the building.



FIG. 01

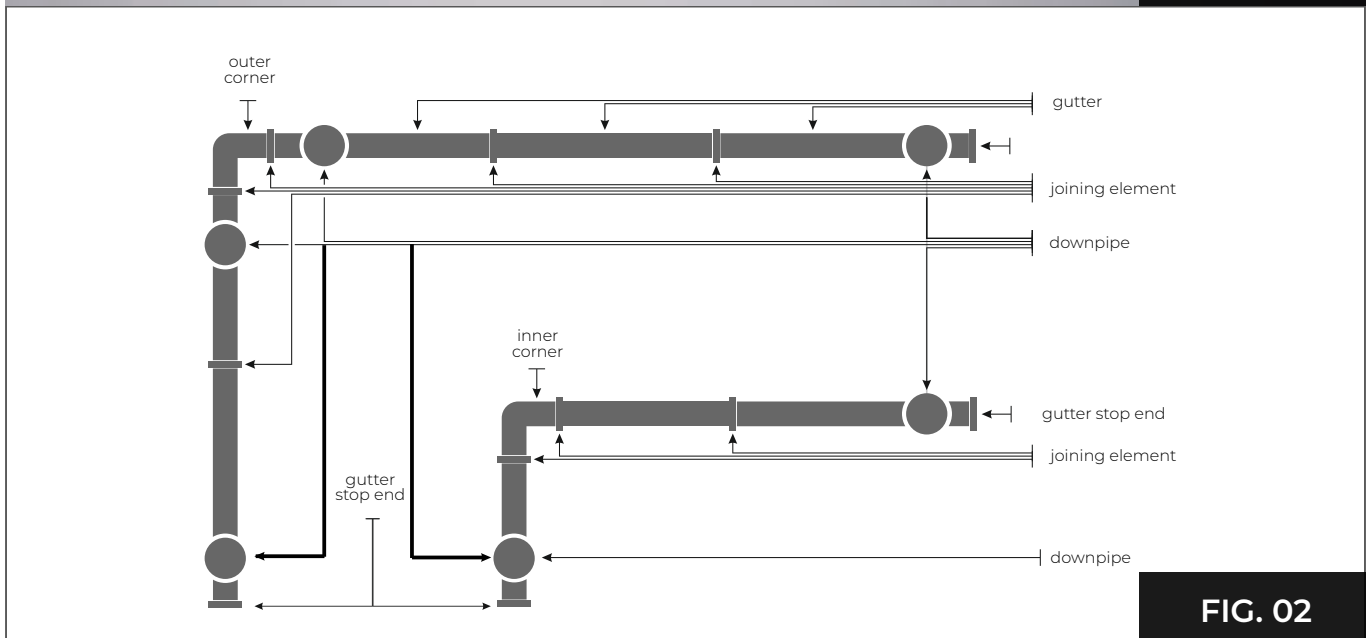

FIG. 02

## STEP 3 - MARKING OF THE HOOKS

### 1 SELECTION OF THE HOOKS

The 210 mm long-tail hooks are installed underneath the cover on each rafter and bent to obtain the proper slope of the gutter (2-5 mm / 1m). Combi hooks are installed directly on the front plank or beam, keeping a proper slope of the gutter (2-5 mm / 1m).

Below you'll find an example of how 210 mm hooks are installed:

### 2 MARKING OF THE HOOKS

- shall be made considering the gutter's drainage points that guide the water towards the downspout, and the recommended slope of the gutters – 2 to 5 mm / 1m.
- the number of hooks required shall be calculated taking into consideration that they will be installed on each rafter (recommended distance between the hooks: 600-900 mm).

Marking shall be performed as follows:

- the required hooks are aligned (FIG. 03)
- each hook is numbered in the order they will be installed on the roof (FIG. 04)

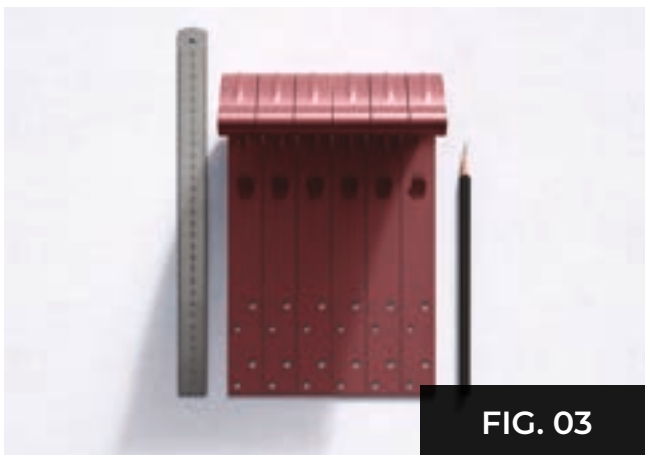

- a perpendicular line is drawn on each aligned hook (FIG. 06) and the marking shall consider the minimum bending rate of the hooks - 40 mm (this is the length of the device used to bend the hooks (FIG. 05)).



## STEP 3 - MARKING OF THE HOOKS

- The location of the downspout is marked (FIG. 07)  
(in this example the downspouts will be installed next to the first and the last hook).
- “ The recommended slope of the gutters – 2 to 5 mm / 1m.
- The highest and lowest points are marked – the slope of the gutter (FIG. 08).

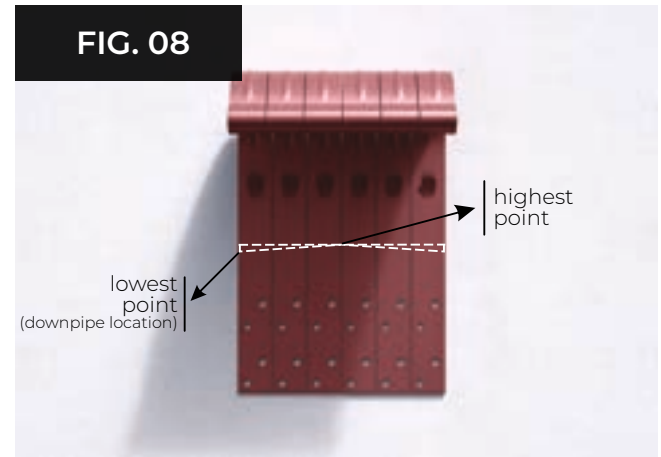
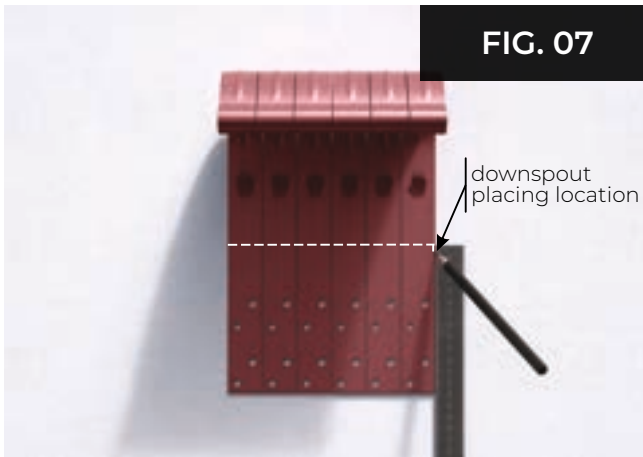

## STEP 4 - BENDING AND INSTALLATION OF THE HOOKS

### BENDING OF THE HOOKS

The hooks marked at Step 3 will be bent using special pliers for bending hooks (FIG. 09).

The hook is positioned in the pliers taking into consideration the previously drawn slope line (FIG. 10, 11).

“ The bending degree of the hook is determined depending on the roof, so as to have the hook in perfectly horizontal position at installation. (FIG. 12, 13, 14)

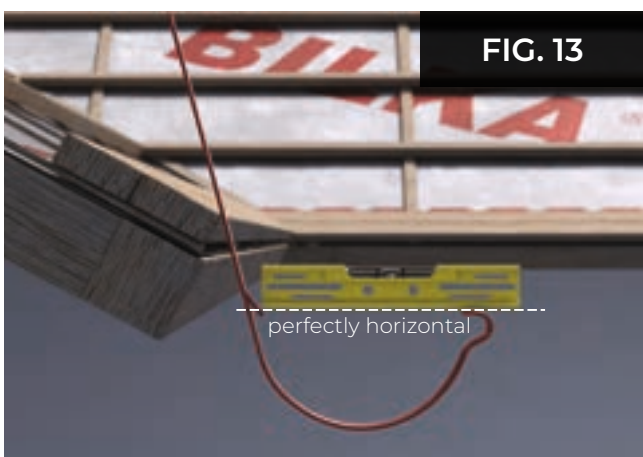
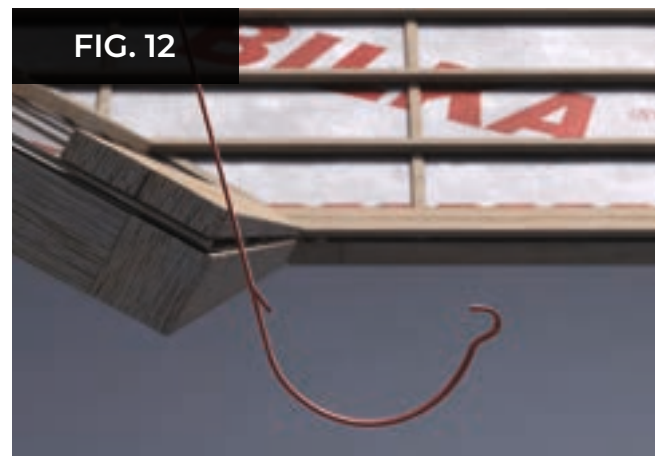
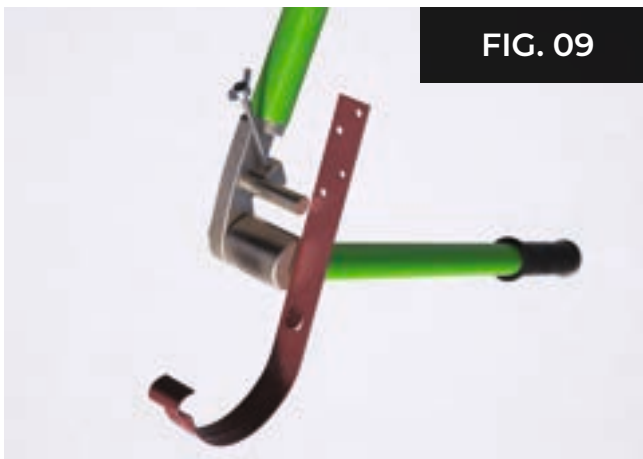

## STEP 4 - BENDING AND INSTALLATION OF THE HOOKS

### INSTALLATION OF THE HOOKS

- Before being fastened, the hook is positioned taking into consideration the marked slope line (FIG. 17, 18).
- A hook is installed on each rafter - distance between hooks 600-900 mm (FIG. 17, 18).
- The hooks are fastened using wood screws or nails, in each hole provided from factory on the hooks (FIG. 15).
- If corners are used, place one hook on each side of the corner (FIG. 16).

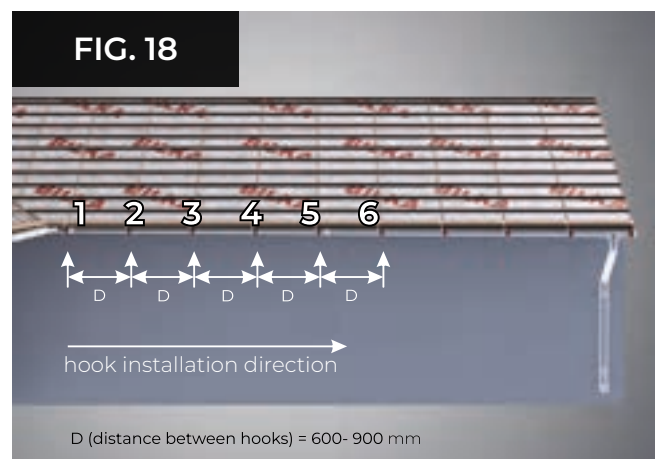
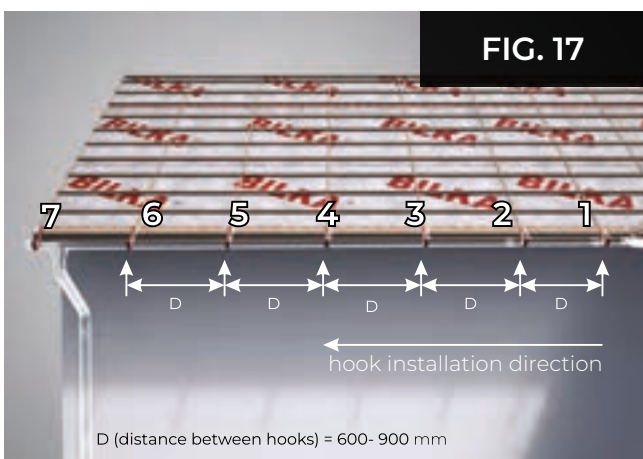
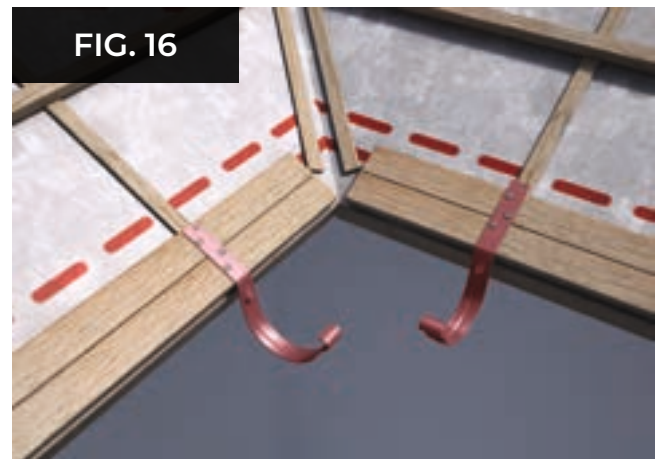

## STEP 5 - INSTALLATION OF THE CORNERS AND SIZING OF THE GUTTER

**1** The corners are installed before the installation of the gutter. Position the end of the corner facing the rain shadow in the spur on the hook and then press the outside edge into the lock. (FIG. 19, 20).

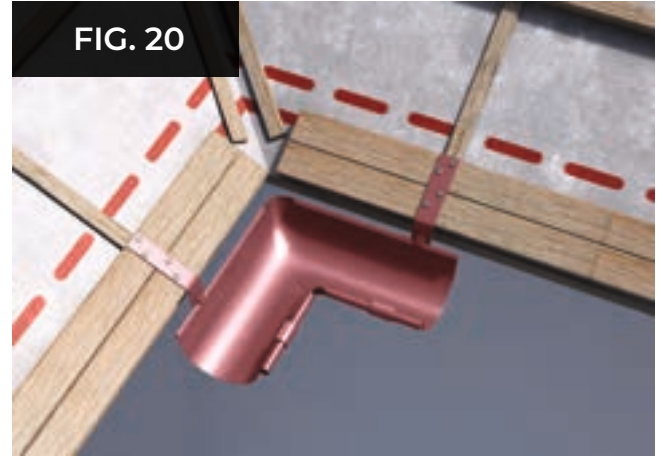

**2** Measure the required size for the gutter (FIG. 21). The gutters and corners are placed keeping a distance of 1-2 mm to compensate for the trough expansion and contraction of the gutter due to changes in temperature. (FIG. 22).

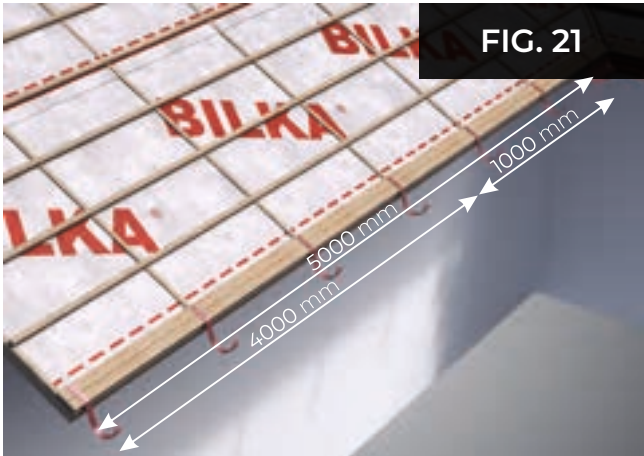

**3** Mark the gutter (FIG. 23) and cut it with a hacksaw (FIG. 24) - do not use abrasive blade / flex.

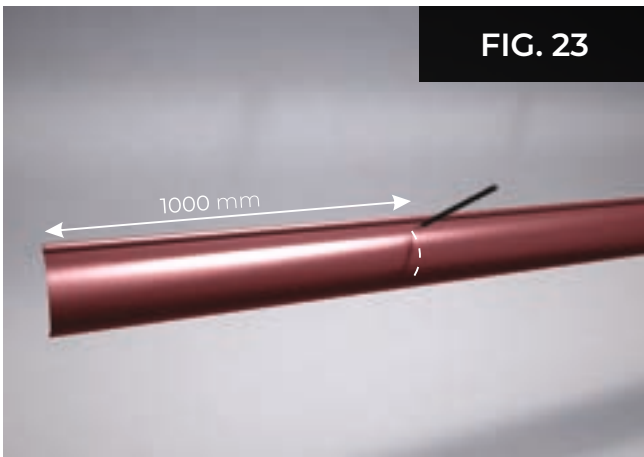

## STEP 6 - CUTTING THE GUTTER – RUNNING OUTLET

Place the gutter on the supporting hooks without fastening it.

On the gutter, mark the point where the running outlet is to be installed (FIG. 25), then mark the gutter, taking into consideration the size of the downspout (90 mm or 100 mm) (FIG. 26).

“ This is the place where the collection points will be located.

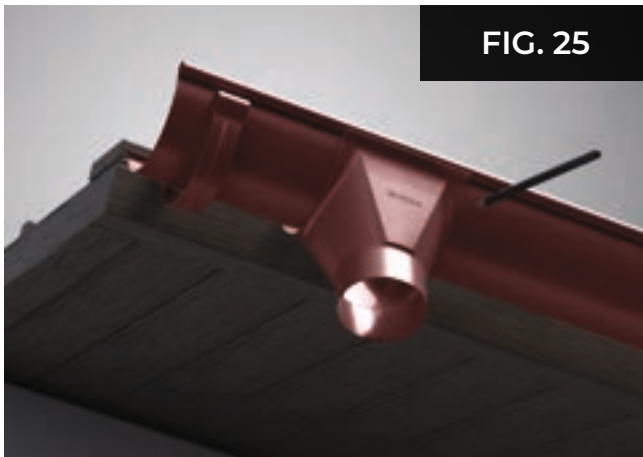

Use a hacksaw or manual scissors to cut following the marking (FIG. 27, 28).

“ **WARNING:** do not use a circular saw / flex for this.

Bend the cut edges outward, to allow water to be discharged to the header (FIG. 29).

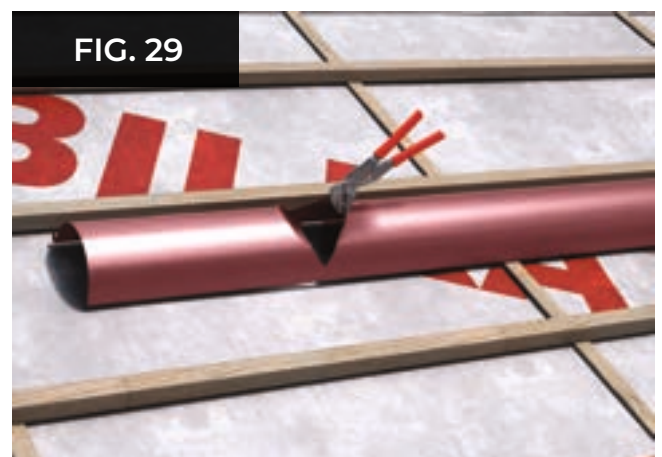
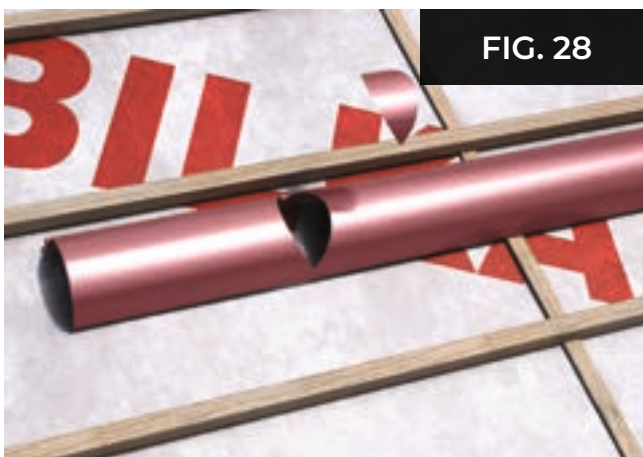

## STEP 7 - INSTALLATION OF THE GUTTER AND RUNNING OUTLET

- 1 Install the gutter by inserting the end facing the rain shadow in the spur on the hook and then press the outside edge into the lock. Then install the other gutters. (FIG. 30, 31)

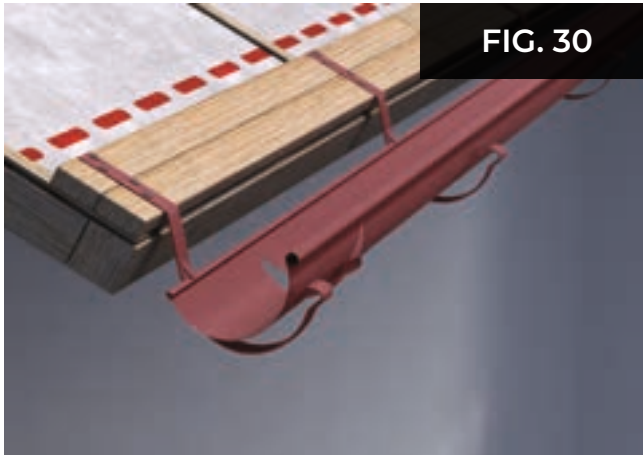

- 2 Install the running outlet by inserting its bent edge into the outside channel of the gutter. Push the funnel to the inside to integrate the gutter and secure it by bending the safety tabs onto the gutter (FIG. 32, 33, 34, 35).

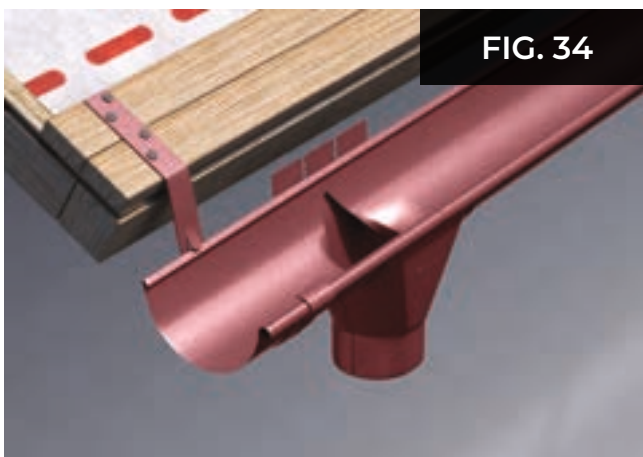

## STEP 8 - INSTALLATION OF THE GUTTER STOP END

Install the stop ends at the ends of the gutters using a rubber hammer, thus fastening the gutter in the channel fitted with the stop end from factory. (FIG. 36, 37, 38)

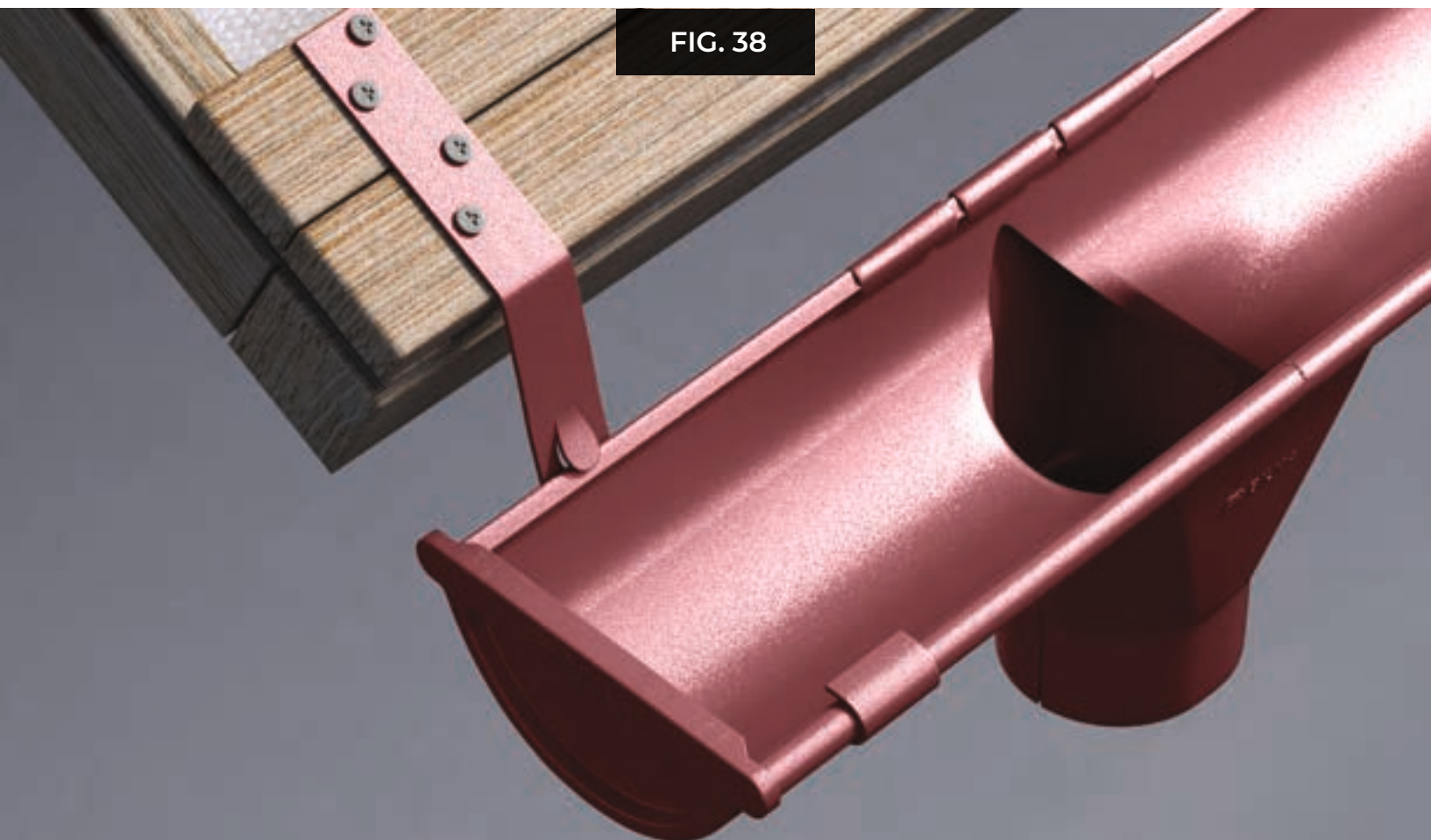

## STEP 9 - INSTALLATION OF THE JOINING ELEMENT

Install the connector starting from the back of the gutter, so as to have the gasket at the joint between the two gutters or between the gutter and the bracket (FIG. 39, 40).

Then place and close the clamp of the piece on the front side of the gutter (FIG. 41).

Secure it by bending the safety tab fitted from factory on the piece (FIG. 42).

“ Further fasten the connector by wood screws in each hole of the piece provided from factory (FIG. 43, 44).

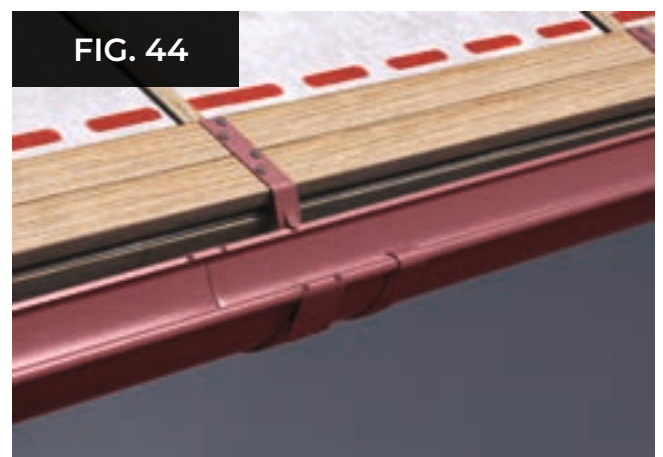
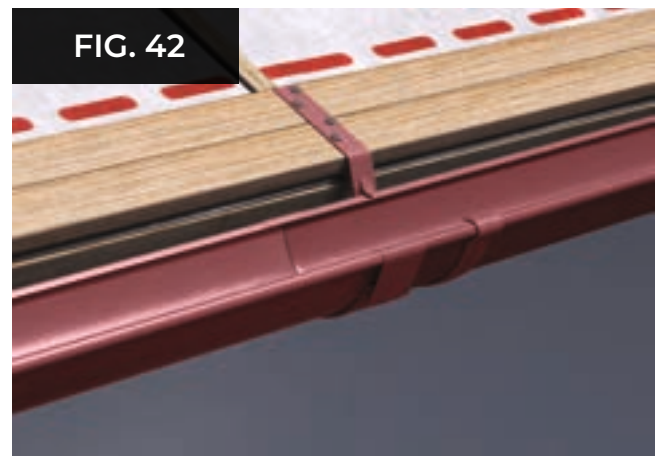
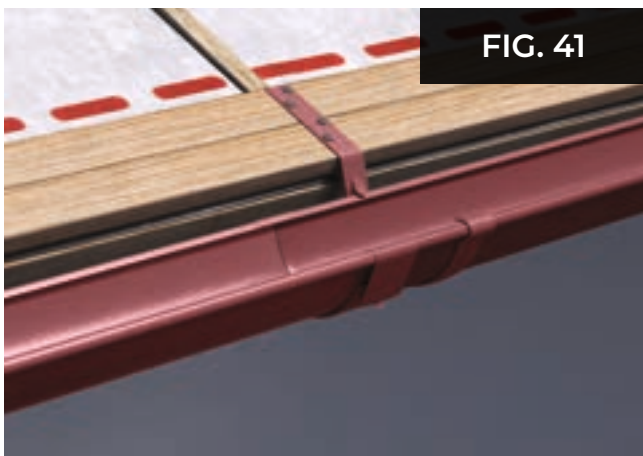
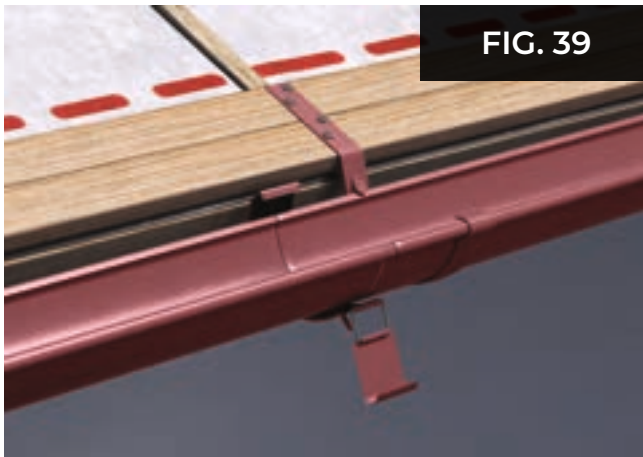

## STEP 10 - INSTALLATION OF THE DOWNPIPE CLAMP

Fasten the downpipe clamp on the façade of the building using wood screws / dowels, depending on the finishing of the façade. Install it in line with the running outlet (FIG. 45).

- “ depending on the length of the downspout, install one or more clamps on the same line.
- “ the distance between two clamps should not exceed 3 meters.

If it is necessary to join two downspouts, one downpipe clamp shall be installed at the joint.



FIG. 45

After the downspouts are positioned in the clamps, insert the safety nibs in the two guides fitted on each clamp from factory.

- “ Use a rubber hammer to fully insert the nibs, and provide rigidity to the downspouts.. (FIG. 46)

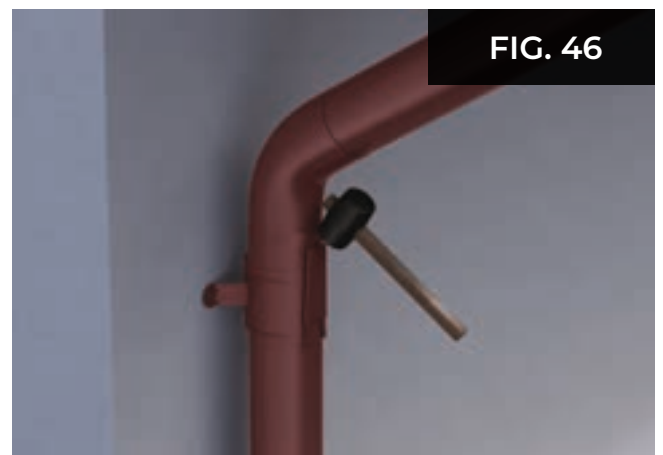
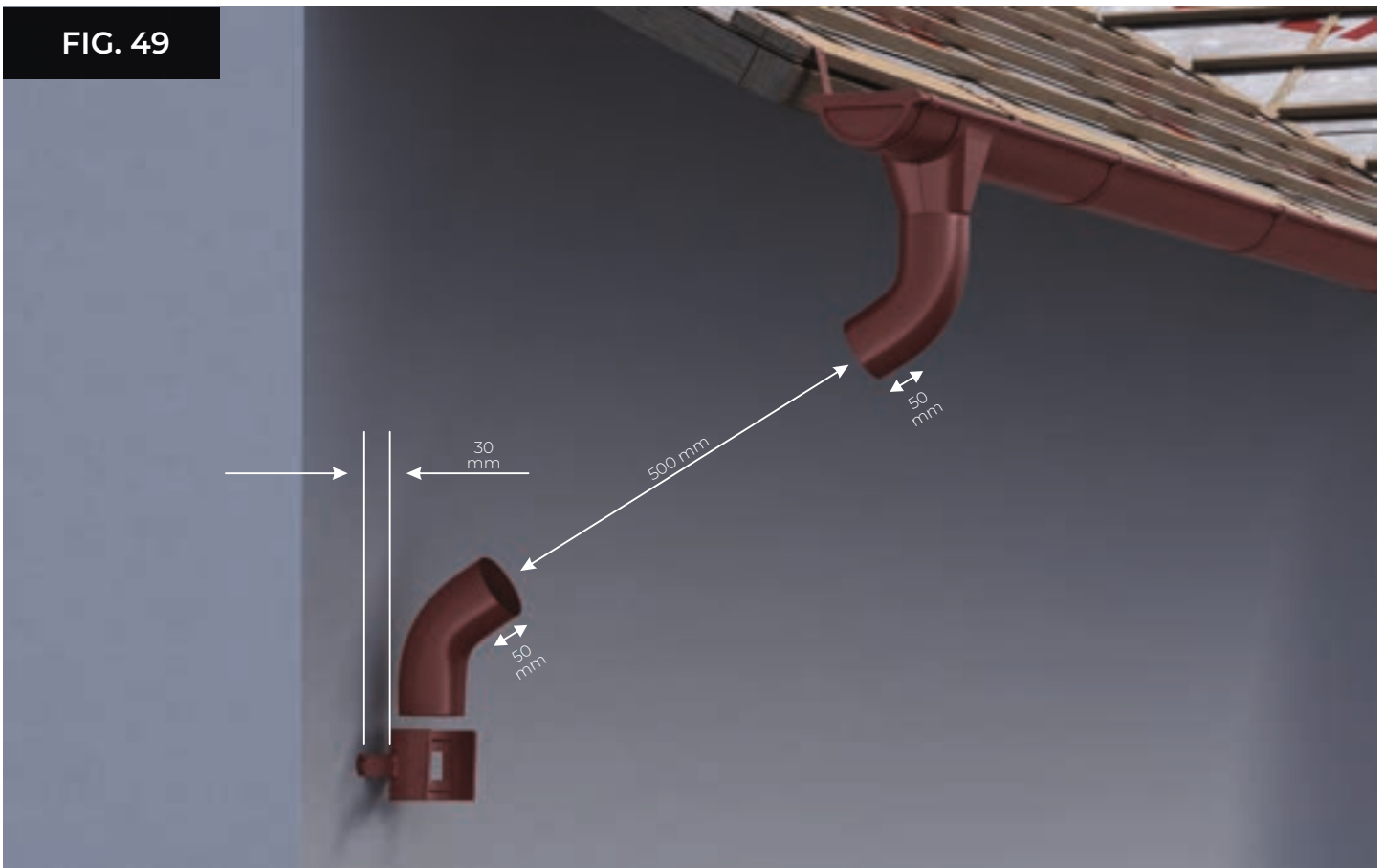

FIG. 46

## STEP 11 - INSTALLATION OF THE 60 DEGREE ELBOW / DOWNSPOUT / DISCHARGE ELBOW

**1** Connect the 60 degree elbow to the funnel if the rain shadow of the house exceeds the level of the wall (FIG. 47).  
If the rain shadow of the house does not exceed the level of the wall, the downspout must be connected directly to the running outlet, as the elbow is no longer needed.

**2** Connect the 60 degree elbows using intermediate pipes.  
In order to determine the length of the intermediate pipes, place the second elbow at a distance of 30 mm from the wall, without fastening it (as this is the length of the supports of the downpipe clamp) and measure the distance between the two elbows. (FIG. 48, 49)



## STEP 11 - INSTALLATION OF THE 60 DEGREE ELBOW / DOWNSPOUT / DISCHARGE ELBOW

**3** In order to size the intermediate pipe that connects the two elbows at the length measured in **FIG. 49** (500 mm) add 100 mm (50 mm + 50 mm for the joining areas at the two ends of the intermediate pipe) (**FIG. 50**).

Cut the intermediate pipe with a hacksaw to the calculated size. Always measure from the crimped side of the intermediate pipe provided from factory.

} Do not use a circular saw / flex for this (**FIG. 51**)

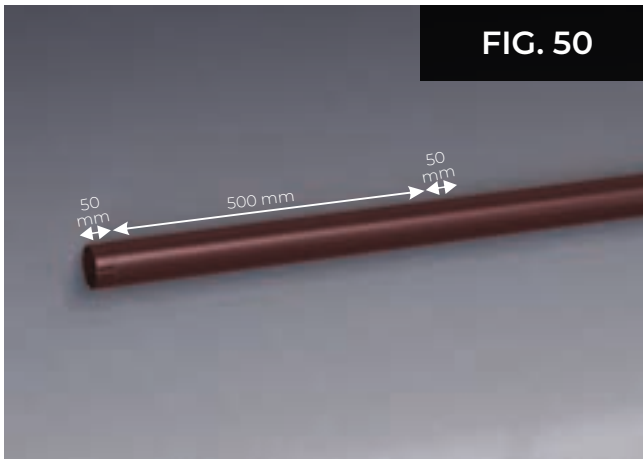

## STEP 11 - INSTALLATION OF THE 60 DEGREE ELBOW / DOWNSPOUT / DISCHARGE ELBOW

Join the two elbows using the intermediate pipe in the direction of the water flow, and fasten them on the running outlet (FIG. 52).

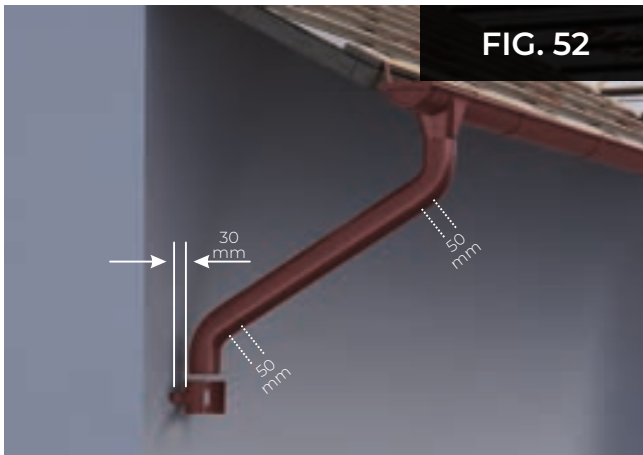

**FIG. 52**

Once the elbows and the intermediate pipe have been installed, the downspout must be sized as follows:

**a** To determine the length of the downspout, place the discharge elbow at a distance of 30 mm from the wall without fastening it (as this is the length of the supports of the downpipe clamp) and measure the distance between the discharge elbow and the 60 degree elbow installed previously (FIG. 53). Place the discharge elbow at a distance of 100 mm from the ground.

- Similarly as when sizing the intermediate pipe, in case of the downspout add 100 mm to the distance measured between the discharge elbow and the 60 degree elbow.
- “ 50 mm + 50 mm for the joining areas at the two ends of the downspout.  
(FIG. 54)

**b** Cut the downspout with a hacksaw to the calculated size. Always measure from the crimped side of the downspout provided from factory.

- “ DO NOT use a circular saw / flex for this.

**c** Install the discharge elbow on the downspout, join the downspout with the elbow installed on the intermediate pipe and fasten it on the wall by closing the downpipe clamp.

- The clamp is closed by inserting the safety nibs in the two guides fitted on each clamp from factory.
- “ Use a rubber hammer to fully insert the nibs.  
(FIG. 55)

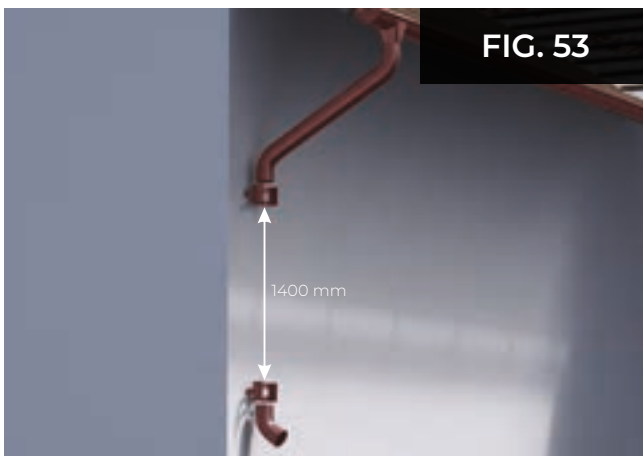

**FIG. 53**

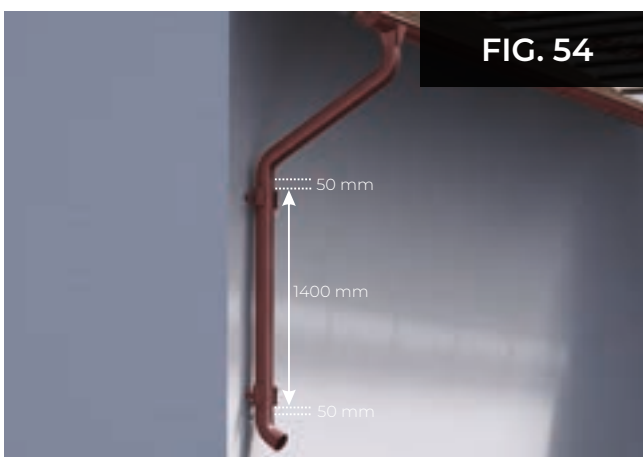

**FIG. 54**

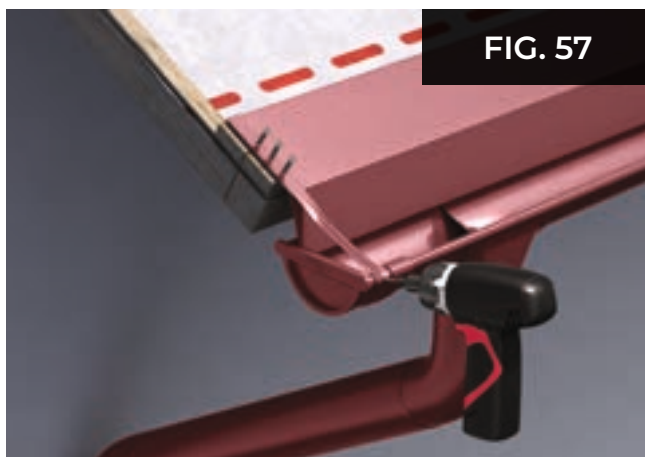
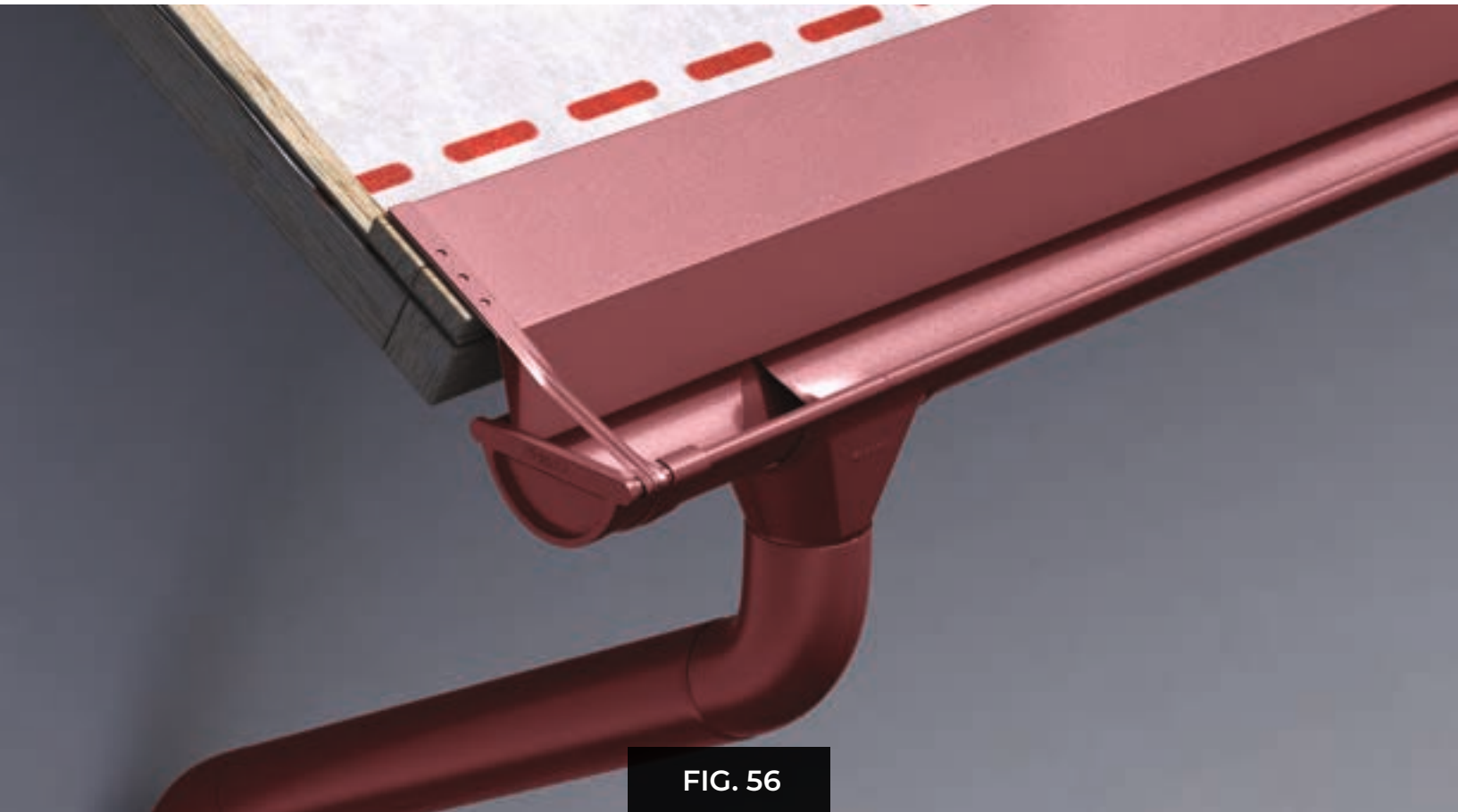

**FIG. 55**

## STEP 12 - INSTALLATION OF THE GUTTER FLANGE

A gutter flange must be installed next to each hook, over the rain shadow edge (FIG. 56).

- Fasten the flange to the rain shadow using self-tapping flat head screws, in each hole provided from factory on the flange (FIG. 57).
- Fasten the flange to the gutter using self-tapping screws with gaskets (4.8x19), in each hole provided from factory on the flange (FIG. 58).





 **BILKA**<sup>®</sup>  
• roof system • rain system •

Scan the QR Code



for details about  
gutter system elements

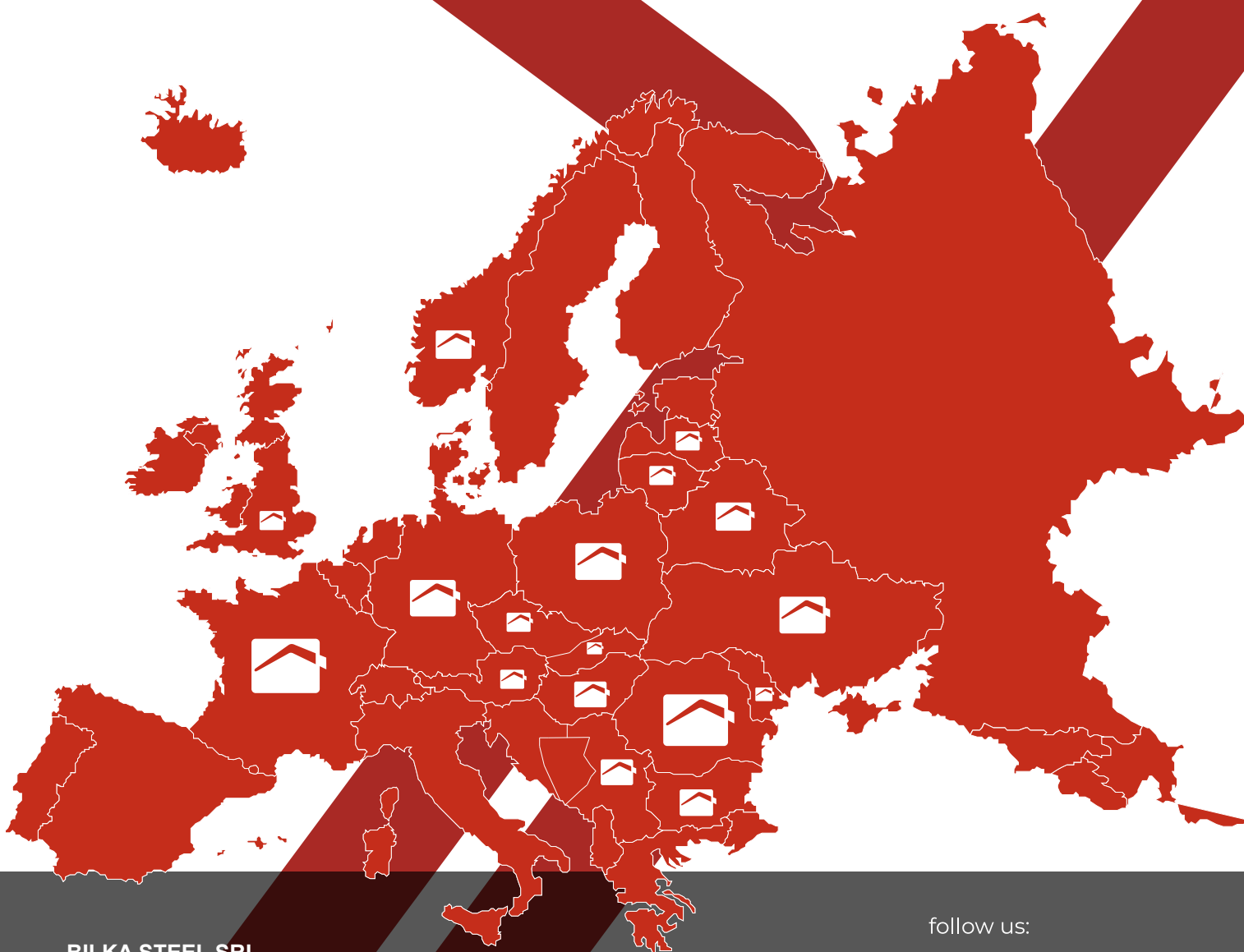

**BILKA STEEL SRL**

Address: Henri Coandă St. No. 17, Braşov  
Phone: +40 733 30 30 30  
Fax: +40 268 548 116  
E-mail: [office@bilka.ro](mailto:office@bilka.ro)

follow us:



[www.bilka.com](http://www.bilka.com)